



POMA |  PURE 

PURE

L'esprit pionnier, réinventé.
The pioneering spirit, reinvented



Une cabine n'est jamais seulement un objet.
C'est une promesse de mouvement.
Un geste d'architecture dans le paysage.
Une expérience partagée.
PURE prolonge un héritage.
Et ouvre une nouvelle génération de voyage.

*A cabin is never just an object.
It is a promise of movement.
An architectural gesture within the landscape.
A shared experience.
PURE builds on a legacy.
And opens a new generation of travel.*



PURE

PURE

PURE

Un mot simple.
Universel.

PURE évoque l'essentiel.
La clarté.
La précision.
L'évidence.
Une cabine débarrassée du superflu.
Réduite à ce qui compte vraiment.

PURE n'est pas une forme.
C'est une intention.

*A simple word.
Universal.*

*PURE evokes essentials.
Clarity.
Precision.
Obviousness.
A cabin stripped of excess.
Reduced to what truly matters.*

*PURE is not a shape.
It is an intention.*





Héritage
Legacy



*Il s'agissait de saisir le caractère
d'un héritage...*

*The intent was to capture the character
of a legacy...*



*...et de dépasser la mémoire
pour en garder l'essence.*

*...and to move beyond memory to
preserve its very essence.*

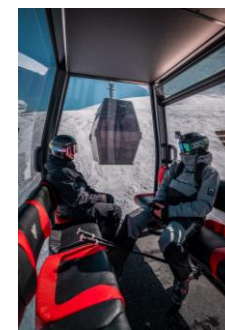

Écouter avant de dessiner

Listening before drawing

Avant de dessiner, nous avons écouté.
 Des exploitants.
 Des techniciens.
 Des territoires.
 Des passagers.
 Des années de retours d'expérience.
 Des milliers d'heures d'exploitation.
 Chaque contrainte exprimée est devenue
 une opportunité d'amélioration.
 PURE n'est pas née d'une page blanche.
 Elle est née du réel.

*Before designing, we listened.
 Operators.
 Technicians.
 Territories.
 Passengers.
 Years of feedback.
 Thousands of operating hours.
 Every constraint expressed
 became an opportunity for improvement.
 PURE was not born from a blank page.
 It was born from reality.*



L'intention

The intention

Une icône n'est pas un souvenir.
C'est un point de départ.
Nous aurions pu styliser le passé.
Nous avons choisi de le questionner.
Chaque ligne a été redessinée.
Chaque fonction réinterrogée.

*An icon is not a memory.
It is a starting point.
We could have stylised the past.
We chose to challenge it.
Every line was redesigned.
Every function reconsidered.*

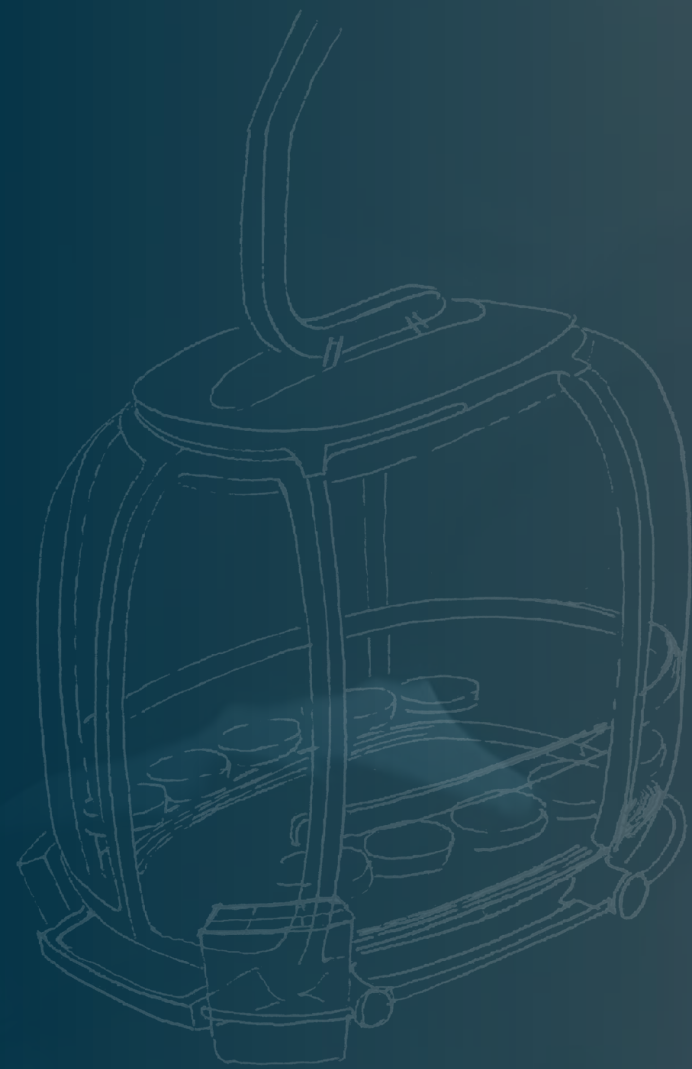



La forme unitaire *The unitary form*

PURE est née d'un dialogue constant entre design et ingénierie.

La forme ne domine pas la technique.
La technique ne corrige pas la forme.

Elles avancent ensemble.

PURE was born from a constant dialogue between design and engineering.

*Form does not dominate function.
Function does not correct form.*

They move forward together.

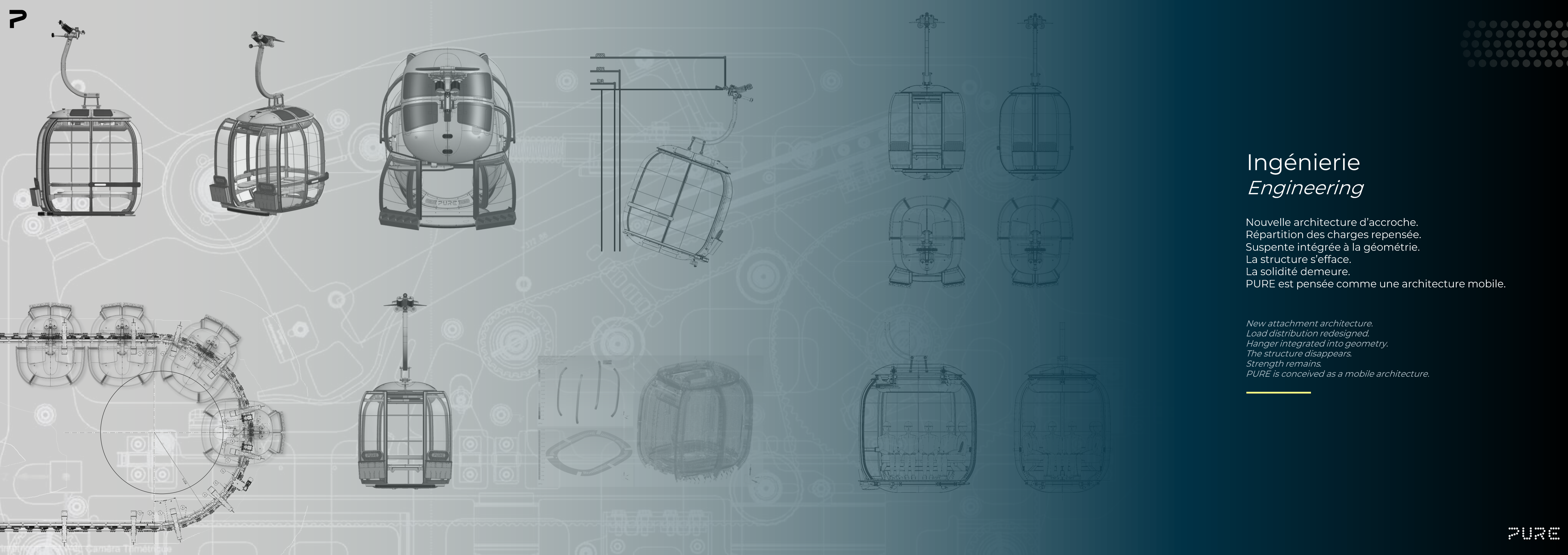

Ingénierie *Engineering*

Nouvelle architecture d'accroche.
Répartition des charges repensée.
Suspente intégrée à la géométrie.
La structure s'efface.
La solidité demeure.
PURE est pensée comme une architecture mobile.

*New attachment architecture.
Load distribution redesigned.
Hanger integrated into geometry.
The structure disappears.
Strength remains.
PURE is conceived as a mobile architecture.*

Fabrication

Manufacture

PURE est conçue pour être industrialisée.
Matériaux recyclables.
Assemblage sans collage.

Maintenance pensée dès la conception.
Cette exigence n'est pas théorique.
Elle est issue du terrain.
Chaque détail simplifie l'exploitation.
Chaque choix facilite la maintenance.

Le luxe réside dans la précision.

*PURE is designed to be manufactured.
Recyclable materials.
Adhesive-free assembly.*

*Maintenance considered from the outset.
This requirement is not theoretical.
It comes from the field.
Every detail simplifies operations.
Every choice facilitates maintenance.*

Luxury lies in precision.



La forme *The form*

PURE repose sur une géométrie continue.
Angles dématérialisés.
Montants affinés.
Surface vitrée maximale.
La structure s'efface au profit de l'espace.

*PURE is built on continuous geometry.
Dematerialised angles.
Refined frames.
Maximised glazing surface.
The structure fades away in favor of space.*

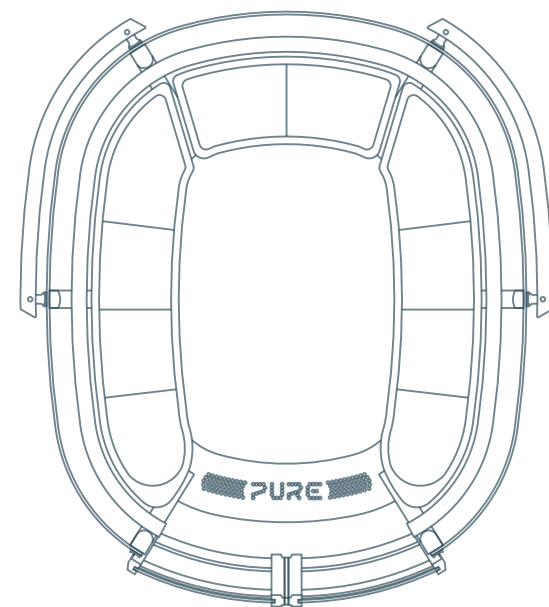
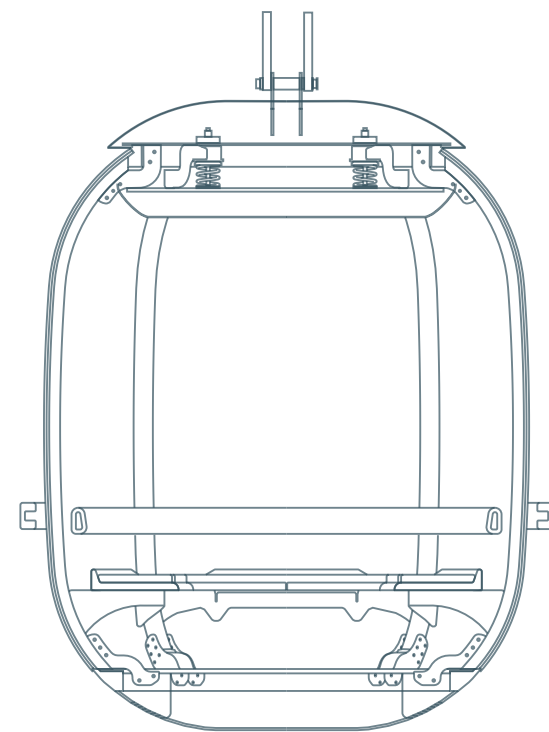

L'espace *The space*

La cabine s'efface.
Le paysage s'impose.

Volume intérieur généreux.
Perspectives dégagées.

L'espace respire.
Ses passagers aussi.
PURE ouvre l'horizon.

*The cabin fades away.
The landscape takes over.*

*Generous interior volume.
Unobstructed views.*

*The space breathes.
So do its passengers.*

PURE opens up the horizon.



Le confort

The comfort

Le confort n'est pas ajouté.
Il est intrinsèque.

L'acoustique est maîtrisée.
La ventilation est renforcée grâce à l'énergie solaire.
La lumière crée une ambiance chaleureuse.

L'espace invite à la convivialité.
Chaque geste trouve sa place.

Ici le confort n'est pas perçu.
Il s'impose avec évidence.

*Comfort is not added.
It is embedded.*

*Acoustics are controlled.
Solar energy enhances ventilation efficiency.
Light creates a warm atmosphere.*

*Space invites connection.
Every gesture finds its place.*

*Here, comfort is not perceived.
It feels obvious.*

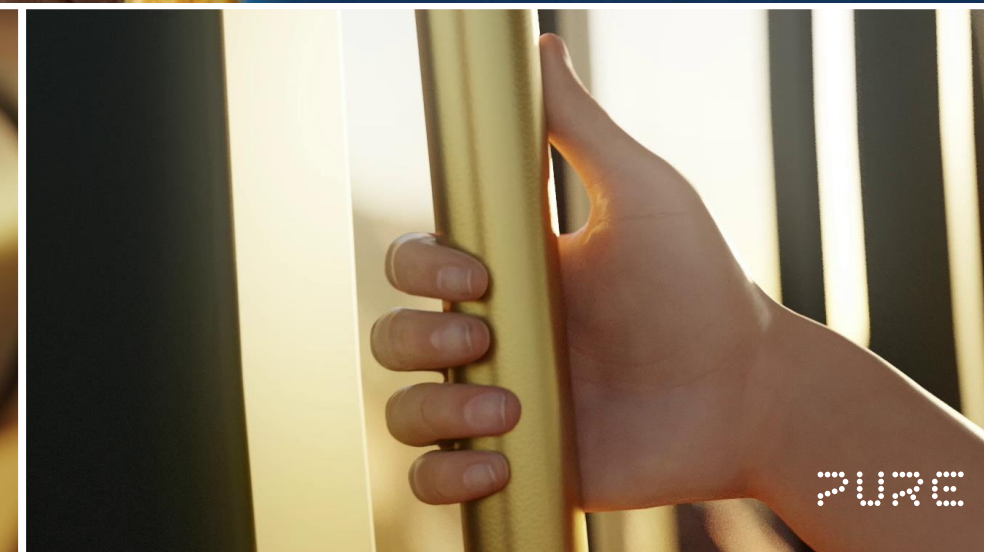
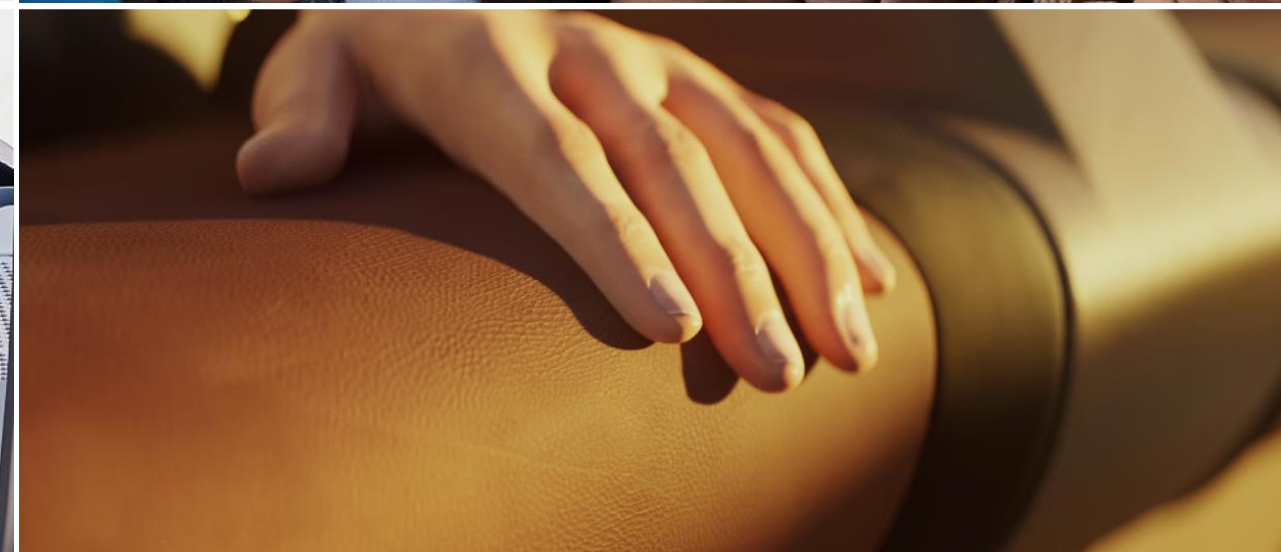

PURE

PURE

Pour tous *For everyone*

Pensée pour tous les usagers.
Sans distinction. Sans adaptation.

Chaque détail est conçu pour accueillir.
Faciliter, fluidifier.

L'espace est une constante.
Le confort aussi.

Certifiée jusqu'à 12 passagers.
Configurée pour 10, par choix.

PURE ne s'ajuste pas à certains.
Elle est juste, pour chacun.

*Designed for all users.
Without distinction. Without adaptation.
Every detail is designed to welcome.
To ease, to flow.*

*Space remains constant.
So does comfort.*

*Certified up to 15 passengers.
Configured for 10, by design.*

PURE is simply right, for everyone.





Ville *City*

Un trajet contemplatif commence.
Un transport quotidien. Une expérience panoramique.
PURE accompagne la transformation des villes.

*A contemplative journey begins.
Daily transport. A panoramic experience.
PURE accompanies the transformation of cities.*





Altitude

Altitude

Le paysage s'élève.
L'expérience se recentre.

*The landscape rises.
The experience turns inward.*



Paysage continu

Continuous Landscape

Le regard circule.
La cabine s'efface.

*The view flows.
The cabin fades away.*





Territoires d'exception

Exceptional regions

Partager le moment.
Un même confort.
Pour tous les rythmes.

*Shared moments.
One comfort.
For every rythm.*





Sites touristiques

Tourist Destinations

Découvrir autrement.
L'itinéraire devient expérience.
Survoler révèle ce que l'on croyait connaître.

*Discover differently.
The journey becomes the experience.
Flying over reveals what seemed familiar.*



Personnalisation *Customizing*

Chaque projet est unique.
Couleurs intégrées à la matière.
Vitrages personnalisés.
Aménagements adaptés aux usages.
PURE déploie une identité forte et multiple.

*Each project is unique.
Colors integrated into the material.
Custom glazing.
Layouts adapted to specific uses.
PURE unfolds a strong, multifaceted identity.*



Personnalisation des augets et grilles de sol
Customisation of trays and floor grids

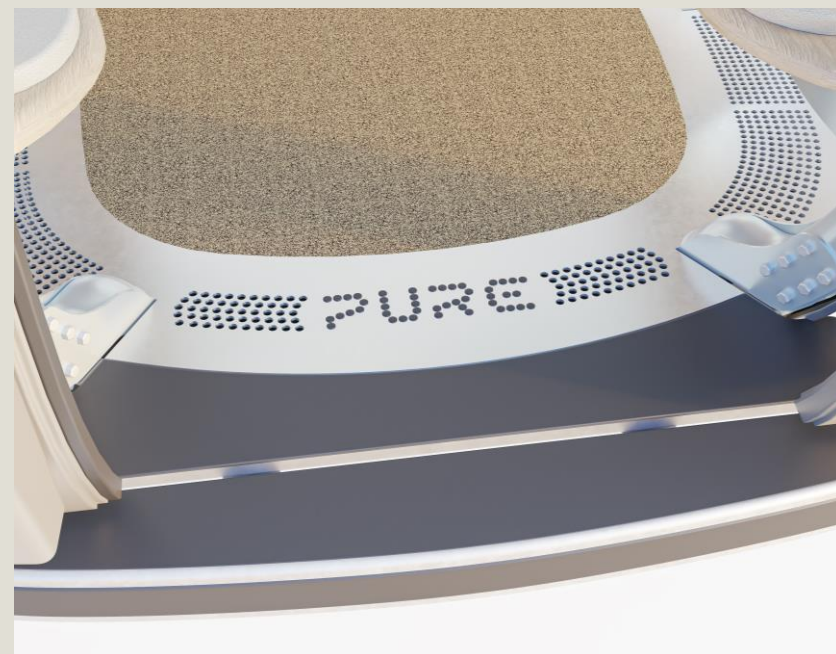

Assises centrales ou contour
Central or contour seats

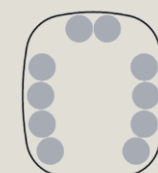
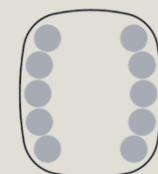
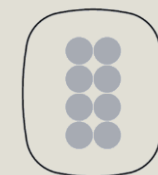

Signature chromatique intégrale
Full chromatic signature



Tout devient possible
Everything becomes possible

Un même confort.
 Pour tous les rythmes.

*One comfort.
 For every rythm.*



Assises unitaires
Single seats

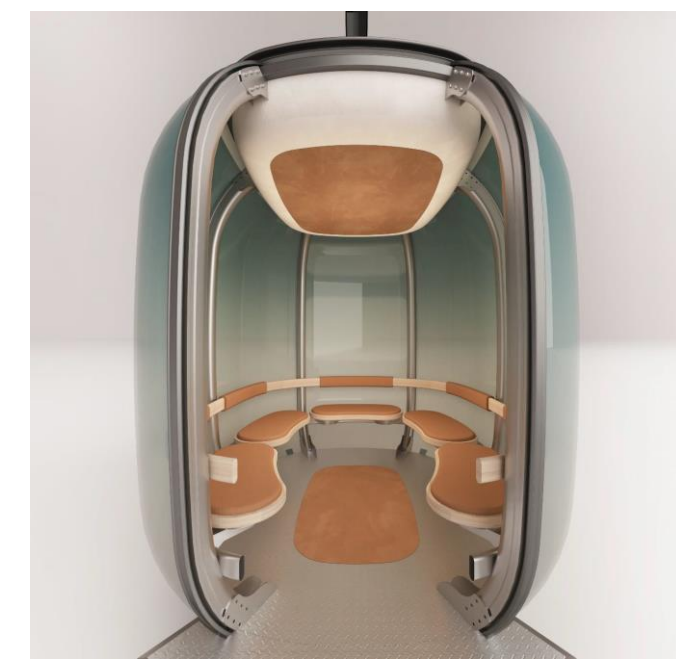

Banquettes duo
Duo benches



Banquette semi-continue
Semi-continuous benches

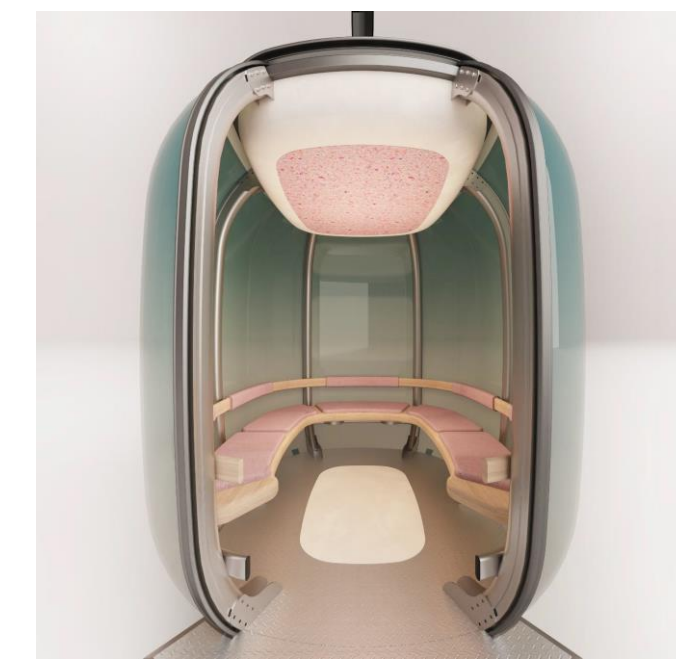

Banquette continue- Assises duo
Semi-continuous benches - Duo benches



Banquettes continues
Continuous benches

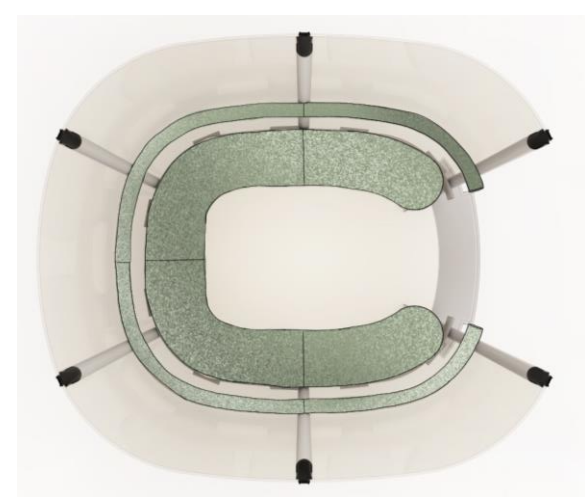
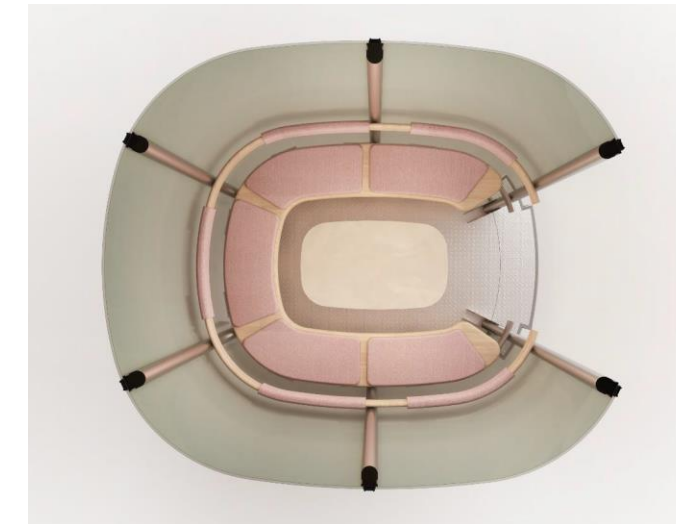
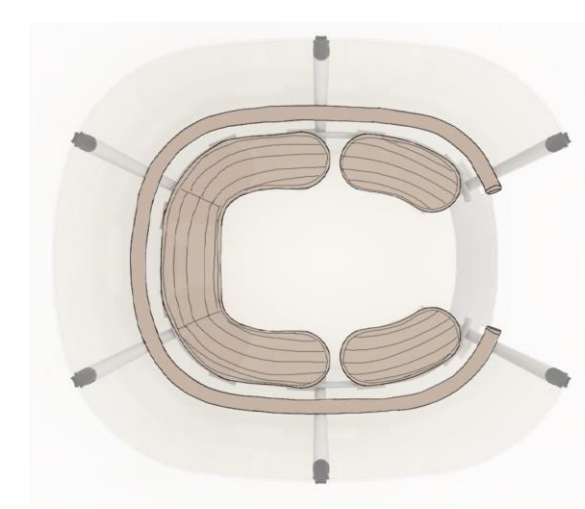
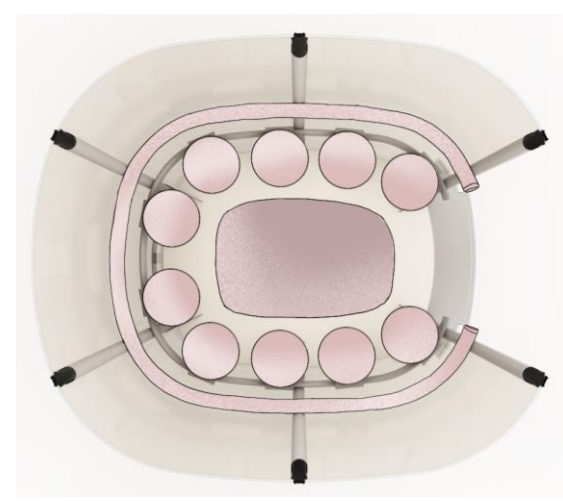

Des équipements illimités

Unlimited equipments



Son de haute qualité
High quality sound

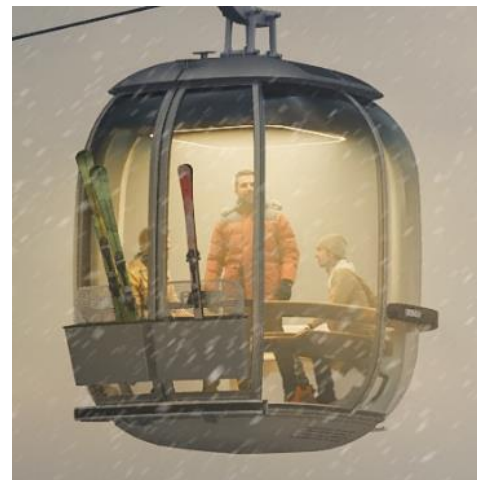

Lumière d'ambiance
Ambient lighting



Caméra de surveillance
Security camera



Intercom
Intercom



Ecran multimédia
Multimedia screen



Augets intérieurs ou extérieurs
Outdoor or indoor trays

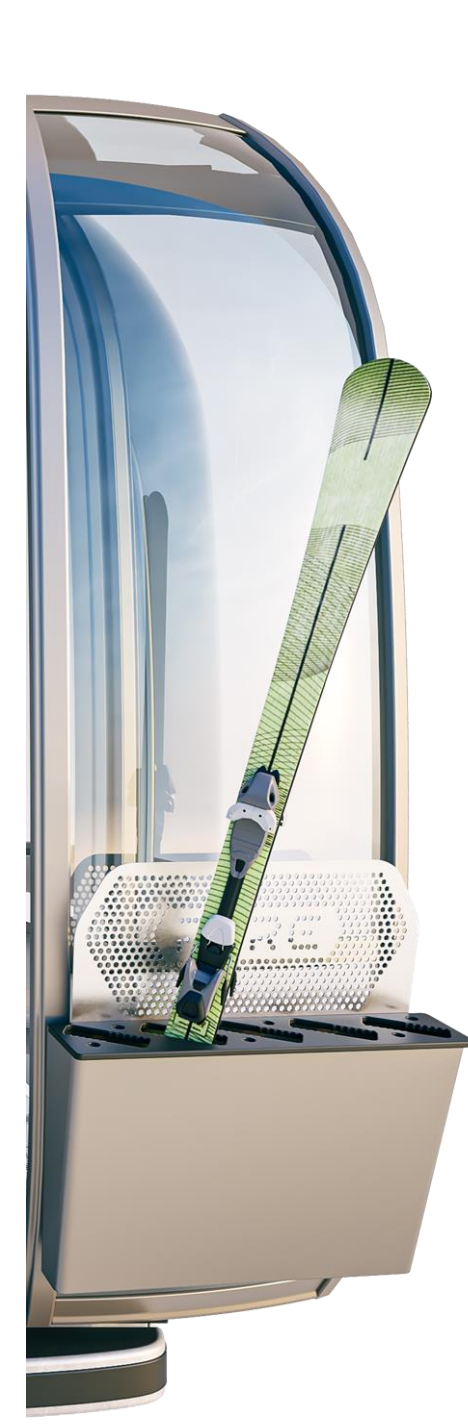

Porte vélo intérieur
Indoor bike rack



Sol transparent
Transparent floor



Dimensions globales

Overall dimensions

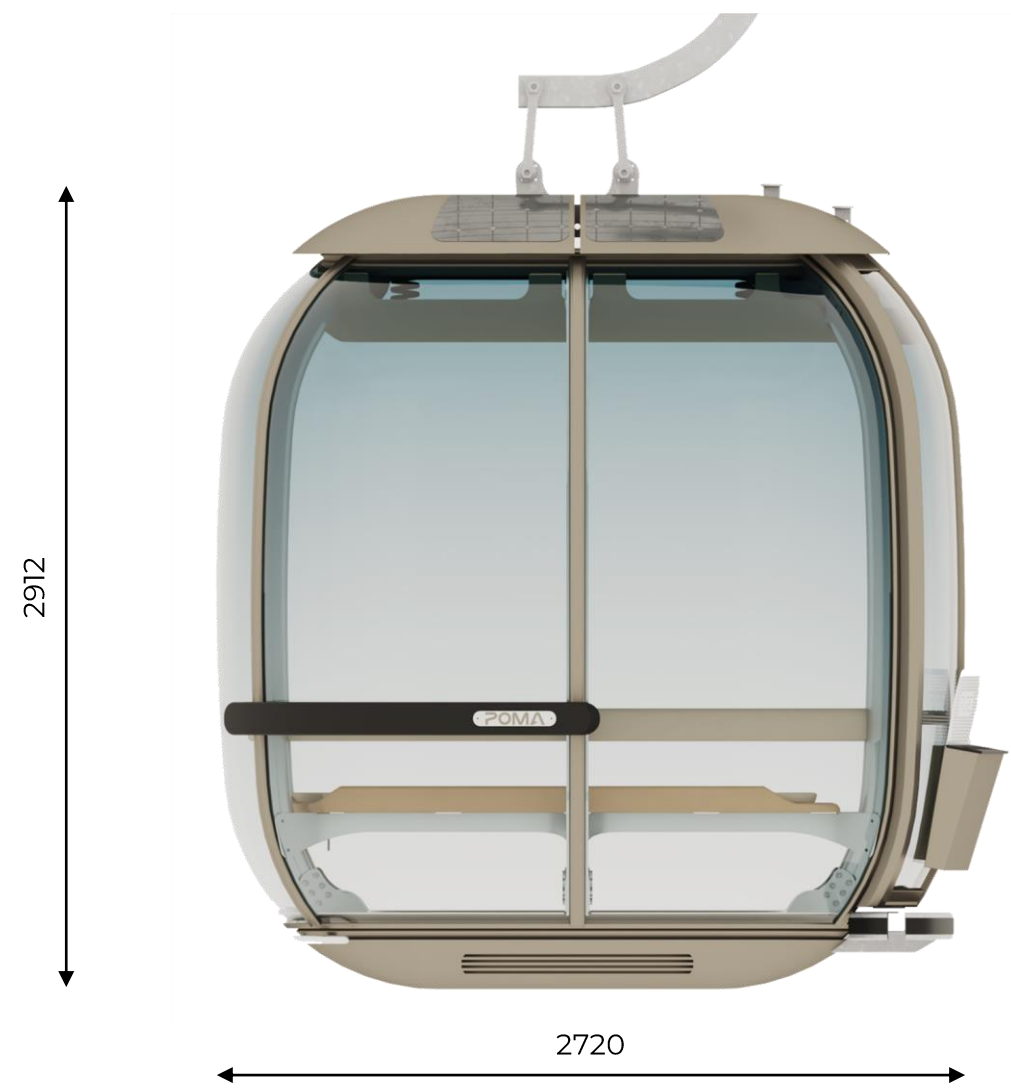
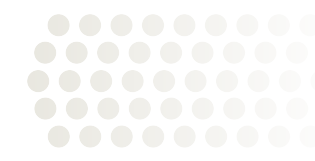

Ouverture de portes
Opening doors



Intérieur
Interior

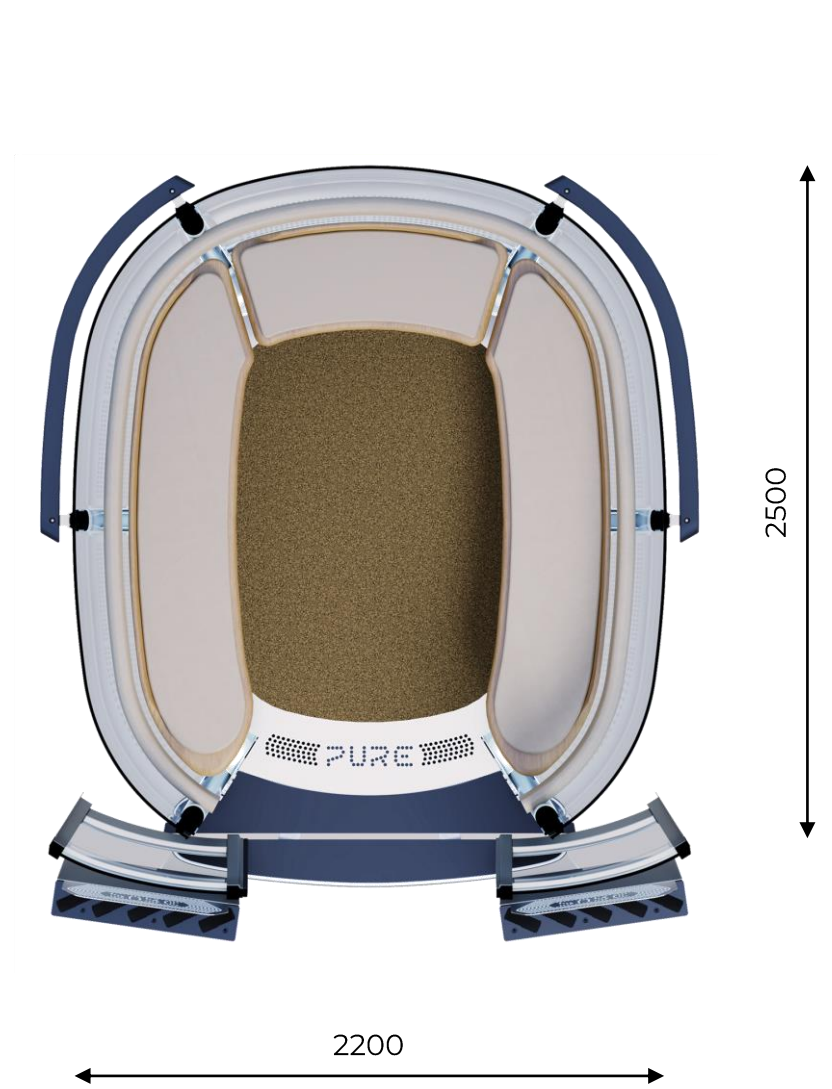

La parole du concepteur *The designer's word*

*« Il ne s'agissait pas de rester dans la mémoire du passé,
mais de la dépasser pour en garder l'essence.
Aujourd'hui, l'imaginaire de la montagne compte autant que la montagne elle-même. »*

*« On ne fait pas qu'une cabine. On fait un véhicule.
La forme englobe tout. Contrairement à aujourd'hui. Les angles n'existent plus.
Ici, la couleur n'est plus portée que par la structure. »*

*« Certaines innovations ne se voient pas, mais elles comptent,
À chaque question technique, une réponse de design. Et inversement.
Il y avait par exemple une vraie attente sur le confort intérieur. »*

*"It wasn't about dwelling on the past,
but moving beyond it to preserve its essence.
Nowadays, the image of the mountain matters just as much as the mountain itself."*

*"We're not just building a cabin. We're building a vehicle.
The form encompasses everything. Unlike today. Angles no longer exist.
Here, colour is no longer dictated by the structure."*

*"Some innovations are invisible, but they matter,
For every technical question, there is a design answer. And vice versa.
There were for example real expectations regarding interior comfort."*

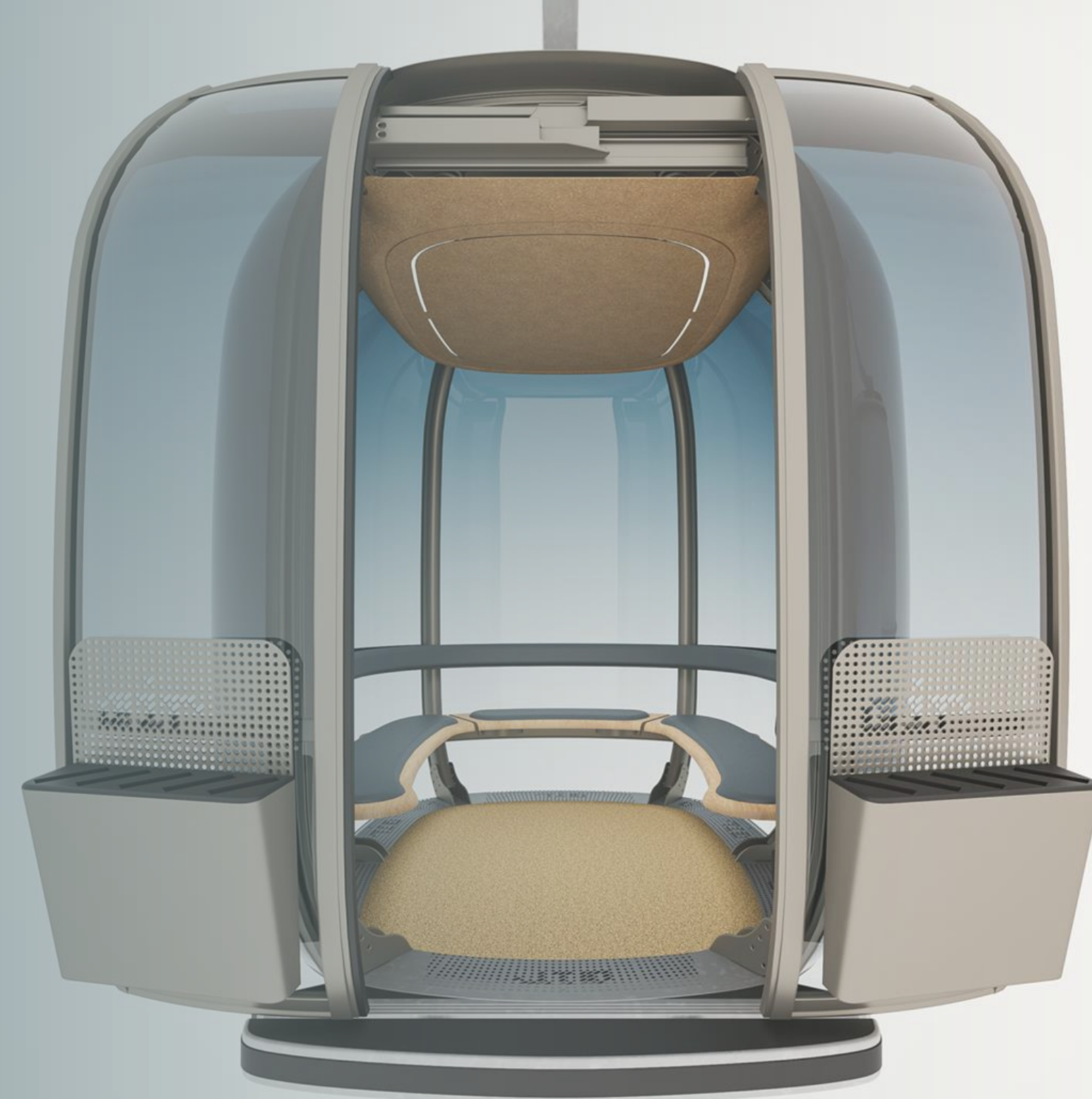



PURE

